

MY EARLY ENCOUNTER WITH LEIBNIZ:

On Monadology

by Lyndon H. LaRouche, Jr.

January 22, 2008

*At my present age of eighty-five, I retain a happily vibrant sense of what are, probably, the remaining productive years now ahead of me. However, I dare not ignore the prudence of saying now what it will be important that I would have said, while the opportunity still remains for me to do so. I sense, thus, the duty of identifying some of the most important among the deeper roots of those most precious conceptions now urgently needed for the use of the leading intellectual strata of representatives of present adolescent and young-adult generations. The origin of the most central, fundamental, and most memorable of those deeper roots of my presently knowledgeable outlook, is to be located in my reaction to a study, dating, from my adolescence, on the subject of Gottfried Leibniz's concept of the **Monadology**.*

That is, essentially, the subject of my concern here.

There are, thus, certain special ideas which I intend, as if each were a poem,¹ to be a heritage to be placed at the disposal of, especially, my wife Helga, with whom I share something special of great value on this account; but, these matters, such as my adolescent discovery of the meaning of

Leibniz's Monadology, must become shared, especially, by all those others among my associates generally, who have committed themselves to faithful promotion of that same kind of intended benefit for all present and future humanity.

*The text of the **Monadology** is, of course, available to those who will seek out its spark of genius; but, the way in which I came to experience it, and to probe its implications ever more deeply over the decades since my adolescence, is an experience which is rarely encountered among those living persons whose world outlook has been dominated by the cultural ruins left by the post-1968 European civilization of today; that will remain the prevalent condition, until more among us do as I have done, work to convey to others, especially the young adult generation of leaders emerging today, a sense of that specific quality of Promethean spark by which men and women may be freed from the chains of Sophistry.*

My Introduction to Riemann

My first significant, and lasting encounter with the work of Gottfried Leibniz, erupted in the context of my adolescent years' virtual "guerrilla war" against the cult of Euclidean geometry. This eruption occurred during the interval between my fourteenth and fifteenth years. Leibniz's *Monadology*, albeit read by me then in translations into English, was the first work to which I became seriously and permanently attached on this account, as if attached to something which I began to recognize then as encompassing the entirety of myself.

This was the subject which occupied most of the pages of my scribbles deposited into those high school recess-periods' notebooks which I filled out during those years. It was the *Monadology* whose specific mode of argument gripped me for reason of its relevance to my already established rejection

1. The principle of Classical poetry, which is to be taken in the sense of Percy Shelley's *In Defence of Poetry*, is a typical reflection of the actual notion of the Pythagorean *comma*. It is the principle of prosody, which governs not only Classical poetry, but also both Classical music in the sense of the Classical principles of Johann Sebastian Bach and his followers, and also plastic artistic composition in the sense of Leonardo da Vinci, Raphael Sanzio, and Rembrandt. Each of those are to be considered as differing geometries, such that the principle of the *comma*, which is also the principle of the Leibniz *Monadology*, is the expression, in each case, of that *characteristic* of that creative potential of the individual human mind which sets the human personality apart from the beasts.



Library of Congress

Gottfried Leibniz derived the calculus as an expression of physical action in the universe: the infinitesimal curvature of physical space-time at any instant. Shown here is some of his work on the catenary function, which was crucial to his development of the calculus. (Curve FAL on the diagram—the shape made by a hanging chain.)

FIGURE 1
Leibniz's Construction of the Catenary and Logarithmic Curves

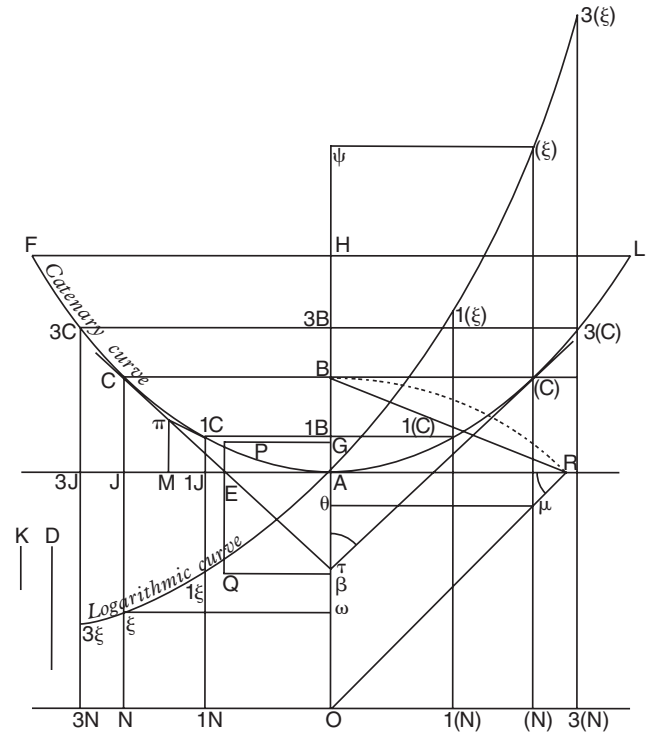

Source: *Fidelio*, Spring 2001.

of what passed for the teaching of Euclidean Plane Geometry, as later, of Solid Geometry, and, still later, of so-called Cartesian (“Analytic”) Geometry, and, then, the perverted, Cauchy version of the Differential Calculus.

As I have publicized fragments of reports on this subject, scattered among sundry lectures and published writings over the course of, especially, the recent four decades: my rejection of Euclid, at my first classroom encounter with that dogma, reflected conclusions which I had reached in study of constructions which I had observed earlier, at Boston’s Charlestown Navy Yard. At that Navy Yard, I had been struck by the way in which structural beams were crafted to the purpose of increasing the ratio of the weight of the supporting aspects, to total weight of structures supported, supported so, by the manner chosen for the shaping of supporting beams and its structure as a whole.²

Guided by my memory of that important experience I had enjoyed at the Navy Yard, I left the first hour spent in that geometry classroom on the first day of geometry class, correctly convinced that the reductionist method employed by adoption of Euclid’s so-called *apriori* definitions, axioms, and postulates, was essentially (e.g., axiomatically) wrong. This conviction grew into becoming my later years’ recognition that

the origin of Euclid’s hoax was to be located in the influence of the Sophist Aristotle on his relevant follower, Euclid.

It was the foregoing experience which had prompted my virtually allergic rejection of my subsequent high school and university experience of the teaching of Analytic Geometry, and, later, my mind’s refusal to tolerate the axiomatic, reductionist assumptions taught (*to me*) as Differential Calculus at the university undergraduate level. This evidence prompted that same seemingly allergic reaction against a Differential Calculus consistent with the dogmas of Laplace and Cauchy. My happier, although soon interrupted, war-time experience with certain aspects of a course which was taught as Integral Calculus, during classes held at the university during the Autumn of 1942, provided, albeit briefly, unfortunately, at that time, a strong affirmation of the viewpoint which I had adopted some years earlier. This produced my recognition of

2. Consider the recent work done to modify Paris’ Eiffel Tower on this account.



Sami Huhtala

The Eiffel Tower's delicate lattice structure illustrates the youthful discovery made by LaRouche at the Charlestown Navy Yard: that Euclidean geometry does not apply to the physical universe. During the 1980s, the tower was reconstructed to lighten some of the higher parts of the structure.

the need for a truly Leibnizian calculus which would be based specifically on a fully conscious, efficient rejection of the axiomatically reductionist, Sophist, Aristotelean model of Euclid.

It was this same accumulated experience from the 1936-1942 interval, which provoked what proved later to have been my post-war, 1946-47 reaction to the writings of such topics as those damnably reductionist views of such criminals as Aristotle and Euclid on the categorical subject of life. Already, then, I saw life clearly as being necessarily an ontologically specific mode of existence, as in my short-lived attraction to the work of Pierre Le Comte du Noüy, and my subsequent, 1948 reaction against the radically reductionist³ pollution expressed by Professor Norbert Wiener's cultish quackery of "information theory." Thence, I was led, by 1953, from reflections on the essential folly of "information theory," to the adoption of the standpoint of Bernhard Riemann's 1854 habilitation dissertation: a Riemann work whose opening two printed pages had then already sufficed, for what should be recognized as obvious reasons, to touch and excite my soul, then, as in the preparation of this present writing, today.⁴

That experience led to my thereafter growing attachment

3. "Logical positivist" in that lunatic tradition of Ernst Mach and Bertrand Russell echoed by fanatics such as Norbert Wiener and John von Neumann.

4. Cf. Bernhard Riemann, *Über die Hypothesen, welche der Geometrie zu Grunde liegen* (1854), *Bernhard Riemann's Gesammelte Mathematische Werke*, H. Weber, ed. (New York: Dover Publications reprint edition, 1953). Cf pp.272-273.

to the work of what have been often listed, by some academic formalists, under the academically often highly misleading title⁵ of "pre-Socratic" Greek philosophers. This had become my attachment, over the course of time, to the development of those foundations of what was to emerge in history as the valid modern science of Nicholas of Cusa, Kepler, Fermat, Leibniz, Riemann, Vernadsky, and, in his later years, Albert Einstein. This attachment is also, actually, the subject-area identified by the continuity of the pre-Aristotelean (not "pre-Socratic"!) outlook of Plato et al., in opposition to the Sophists such as Aristotle, and against Aristotle's most notable followers in the history of taught science, such as the ancient Sophists Euclid and Claudius Ptolemy, and their modern followers, Paolo Sarpi's Ockhamite Liberals.

Thus, my adopted view, is also to be seen as that anti-Aristotelean, Platonic outlook which I came to share, as this is also expressed for me most clearly, systemically, by such leading Christian Apostles as John and Paul, and by the attack on Aristotle by those apostles' contemporary, the Apostle Peter's associate, Rabbi Philo (Judaeus) of Alexandria.

Thus, for me, as in past times when I had been often seated, during study hours, as during times in the second story Library of the Lynn (Massachusetts) English High School, the experience of having my mind touched with freshly added discoveries, yet once again, and again, from yet another rereading of an English translation from Leibniz's *Monadology*, was a powerful one; those reconsiderations were, in sum, an experience like that of successive blows of breaking through a glass-like prison, a virtual prison of the mind expressed as what passed then for the illusions of contemporary "popular opinion," freeing my mind to explore the real universe outside the pit of conventional indoctrination.

The Subject of Astrophysics

Decades later, during the 1970s and early 1980s, in one outcome of my earlier rejection of Euclid, I concluded that the idea of "universal" could not have been first experienced by the human mind in any other way than that which had been generated within ancient maritime cultures, through such challenges as that of transoceanic navigation conducted by many successive generations, over relatively long passages of time. This conclusion was not merely a valid one, but had critical epistemological significance in my work as a whole, including its underlying role in shaping my progress in development of an original, corrected form of the science of physical economy.

5. And, perhaps, sometimes, intentionally misleading.

For me, the crucial feature of that evidence was, that from out of those evolving maritime cultures which we have come to recognize as developed during a span of many generations of experience of navigation, there was something changing, on a higher level, a process of change which has only begun to produce its true harvest, even now, today.

It is a matter of a process of changing in ways which can not be accounted for as merely perpetual repetitions.

So, the whole universe opened itself up to my imagination, thus, as being for me, explicitly, a universal, *anti-entropic* form of underlying motion of qualitative development.⁶ I saw, that over long lapses of time, especially for sea-going cultures which had been engaged in this work of astro-navigation over many successive generations of changes, that continuing since long, long before my time, changes ordered in a way coherent with the mind typical of the leaders of such a maritime culture, I was obliged, on this account, to shift the primary focus for a scientific outlook, away from a notion of mere observation, as Johannes Kepler had made such discoveries, away from repetition of formulas, to progressive, qualitative changes within what is to be recognized as both repeated only approximately: but, not as simple repetition, but as changes within the characteristic features of what might have been considered, otherwise, mistakenly, crudely, as seemingly repeating processes.

My approach to that effect was guided, and has been ultimately defined by a recurrent sense, that man's knowledge of the universe we inhabit, has the character of a great scientific experiment, an experiment prudently premised on the demonstration supplied by physical economy. That just-stated principle, fairly stated, is that: *the validity of our estimable knowledge of the nature of our universe, is conditional upon the demonstration of the degree of man's willful power to change that universe.* I write, thus, in the sense of the Prometheus Principle defended by Aeschylus: *our knowledge of the universe we inhabit is conditional upon our ability to increase man's willful power to exist in that universe.* Hence, our knowledge of the nature of the universe, is conditional upon proofs located in the power of the human mind, through discovery of true physical principles of *willful* net physical economic progress of the human species as a whole, within the universe. This is the uniquely essential proof required for all valid discovery and use of any scientific principle.

Consider, thus, the physically functional significance of the ancient Pythagoreans who followed Thales in adopting the Pythagorean concept of *Sphaerics* for what we should recognize now as those competent strains of modern Euro-

6. That is to say, that such developmental motion is not a product of action imposed upon fixed states of existence; but, that *that kind of motion* called *anti-entropic development* within the universe, is an *ontologically primary* quality of the universe's very existence: hence, the *ontologically infinitesimal* motion of Leibniz's *Monadology*.

pean science, which are specifically rooted in those ancient developments. This has reflected, thus, a long preceding, pre-history of the evolutionary development of maritime cultures, such as those cultures whose character is embossed upon the history and territory of the Egypt of the Great Pyramid, an ancient legacy from which a culture had emerged to become the dominant culture, in cultural and physical power, per capita and per square kilometer, within that region, thus forming, through aid of that cultural synthesis, the germ of principle which generated a creation known justly as European civilization.

So, all culturally defined parts of the human species as a whole, are shown to possess the inherent, internal aptitude for mankind's increasing of potential relative population-density, and show this in the way best mapped from the ancient Pythagorean standpoint of *Sphaerics* and of Plato. *This expressed aptitude distinguishes the human species absolutely from all other species, a distinction unique to the human individual mind, as defined by an ostensibly immortal quality of healthy human mental life which surpasses mere biological existence, a mode of living which does not exist among the animal populations.*⁷ This fact is most readily apparent to well developed forms of progressive, oceanic maritime culture, as distinct from more strictly land-locked cultures: it is distinguished most simply by that development of physical science which is intrinsically, by its nature, a nature attributable to its principled origins in many millennia of maritime cultures. This view provides us the relatively clearest insight into this crucial distinction of man from beast.⁸

Consider, as an illustration, the essentials of the actual development of the modern infinitesimal calculus, from its launching on that specific initiative of Nicholas of Cusa which I have referenced above, through Leonardo da Vinci, Fermat, Gottfried Leibniz, et al. Consider this as opposed to the fraudulent version of the calculus, that of empiricists such as Leonard Euler, Joseph Lagrange, Laplace, and Cauchy. Recognize the same systemically pathological influence of these empiricists, as being also expressed in the related case of that fraudulent doctrine of so-called "thermodynamics"

7. E.g., man and woman as defined in *Genesis* 1.

8. As I have emphasized in other published locations, there is no simply biological basis for those human mental powers we associate with true cognition. Cognition, like gravitation as discovered by Johannes Kepler, is an expression of what are, in effect, *ontologically transfinite* forms of mental action. It is the expression of a true principle of the universe at large, as gravitation also expresses a different such type of principle, a different principle to which the biological mental apparatus of the human individual has been, so to speak, "pre-tuned." (Where animals lack such resonance.) Thus, repeated successes in solving riddles whose solutions are intrinsically non-linear (i.e., not reductionist) in essential form, by re-enforcing the relevant tuning of the human mental-perceptual apparatus, improves the tuning of the individual cognitive powers of the human mind, as so-called Classical art (e.g., the legacy of J.S. Bach), succeeds, where reductionist modes of argument tend to defeat and to weakening the "tuning" of the human individual mind, and the culture in which the reductionist view is prevalent.

which is posed, still today, not only by the science-illiterate Baby-Boomers who follow the pathways of hoaxsters such as former U.S. Vice-President Albert Gore, but by such among the relatively more respectable so-called “reduction-ists” of modern times, such as Clausius, Grassmann, and, later, the worse followers of the mystical Ernst Mach, the vicious Bertrand Russell, et al.

Today, looking back over my experience of about seven decades, the nub of Leibniz’s *Monadology* should be presented as follows.

1. The Human Mind

As Percy Bysshe Shelley has reminded us, implicitly, as in his *Prometheus Unbound*, of that modern rediscovery of the ancient principle of competent physical science, sometimes called “fire,” which had actually been launched, during the Fifteenth-Century Renaissance, as the modern science which had been launched, chiefly, by Cardinal Nicholas of Cusa.⁹ This continuing development of modern science, has owed much to knowledge of the influence of the surviving fragment of Aeschylus’ *Prometheus Trilogy*, to which Shelley had referred, *Prometheus Bound*. It was Cusa’s discovery of the physical incompetence of Archimedes’ quadrature of the circle, which has been shown to have been the keystone of all competent definitions of modern physical science. What Cusa discovered, thus, and the spread of man’s “knowledge of fire,” for which the Prometheus of Aeschylus’ drama was tortured, are one and the same conception.¹⁰

That conception is the only competent basis for a general practice of science, thus: *that re-discovery by Cusa is the key to all competent modern science, the principle of science spreading from Luca Pacioli’s associate Leonardo da Vinci, through Johannes Kepler, Fermat, Leibniz, and Riemann, into the work of such avowed followers of Riemann as Academician V.I. Vernadsky and Albert Einstein.* That conception, as traced in modern science from Nicholas of Cusa, is what is expressed, and to be recognized as the essential

9. Not to overlook the important contributions by Brunelleschi, the first modern discoverer of the catenary (funicular) principle of physics, and of its application (as to the cupola of Santa Maria del Fiore) during an overlapping time in Florence.

10. Actually, the concept which Cusa discovered, on this account, was a principle inherent in the method of the Pythagoreans and of Plato. Competent scientific method is always to be associated with purely geometric (e.g., analog, non-linear) relations, rather than digital. The problem which Cusa confronted in the case of the mistake by Archimedes, was the effect of the influence of the Sophistry associated with the influence of Aristotle, and of such followers of Aristotle’s Sophistry as Euclid and Claudius Ptolemy. The significance of Cusa’s discovery of this error in the work of Archimedes, is expressed at the center of the uniquely original discovery of modern astrophysics by Johannes Kepler. All competent method in modern science thereafter has been, subsequently, fundamentally premised on that uniquely original founding of modern Astrophysics by Kepler.

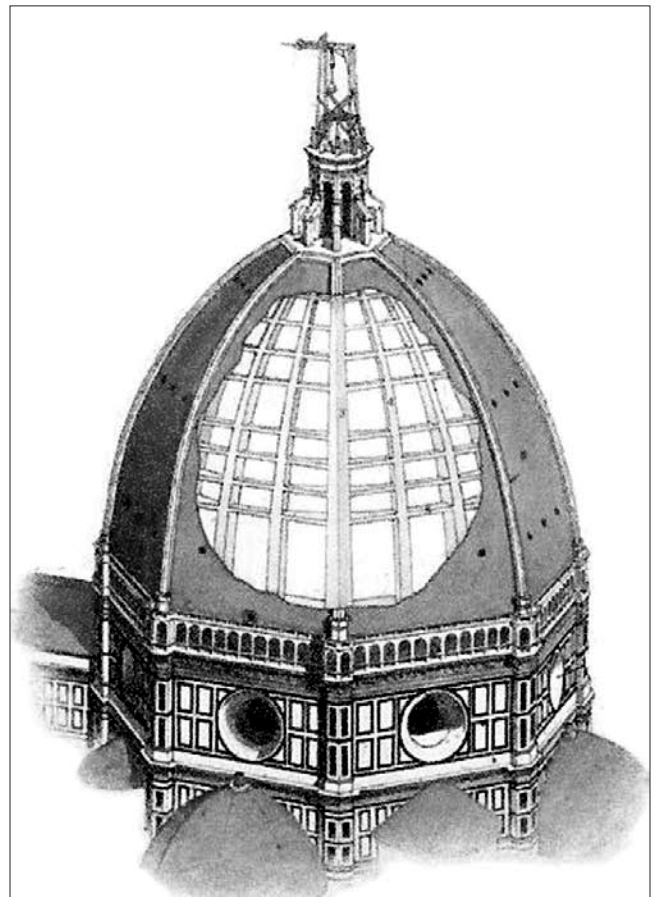

This cutaway drawing of Brunelleschi’s Dome of the Cathedral of Florence (Santa Maria del Fiore) reveals the ribbed structures underneath the wall. The dome was built according to the catenary principle of physics, making possible what had previously seemed to be the impossible construction of this enormous structure.

principle of Leibniz’s *Monadology*. That expresses the true, unique secret of the human mind.

That central principle of all competent physical science is summarized as follows.

In the entire sweep of a competent reading, the foundation of modern Physical Science as such, and the proximate origin of the central concept of Leibniz’s *Monadology*, are rooted in Nicholas of Cusa’s recognition of a crucial, axiomatic fallacy in Archimedes’ quadrature of the circle (and parabola). This was, actually, Cusa’s discovery of *the ontological principle* which Leibniz would present later as the subject of his *Monadology*, and therefore, also, as the central principle of a competent, anti-Euclidean mathematics of *the ontologically infinitesimal*.

I, for one, had learned this principle from my adolescent wrestling with the *Monadology*, that from the standpoint of my categorical rejection of Euclid’s *a priori* presumptions. I came to know this as a general principle of scientific method in a much broader and deeper way, from the crucial 1953 ex-



Cusanus Gesellschaft

Cardinal Nicholas of Cusa was the founder of a systematic form of modern science. Shown here is his torquetum, an instrument for astronomical observations.

perience of my adoption of Riemann's standpoint. During the middle to late 1970s I was enabled to trace this modern conception expressed in Leibniz's work from its deeper origins in the work of Cusa, through my wife Helga's study of the work of Cusa, that through the aid of crucial assistance by the guidance of Fr. Rudolf Haubst and his work as a leader of the Cusanus Gesellschaft. There is no exaggeration expressed by this emphasis on the work of Cusa. He was, in fact, not merely the founder of a systematic form of modern physical science, but was the modern person who introduced that single great principle, as the principle upon which all valid developments in modern science have depended, explicitly, or implicitly, ever since.

Let the point be restated for necessary emphasis, in the following manner: *This discovery, as by Cusa and Leibniz, among others, expresses the centrally underlying, ontological principle of any competent mathematics of physical science. Thus, all competent directions in modern physical science, and related practice, are contingent upon this feature of Cusa's work, as a modern form of an articulated, universal physical science which now depends absolutely on the break-*

through which Kepler supplied to the advantage of his successors.

Thus, true science is not the mere observation and description of our experience of nature. Science properly comprehended, is also a centrally underlying principle of the cognitive powers which distinguish the creative scientific and artistic potential of the human mind from what might be described, loosely speaking, as the "mental life" of the beasts. It is the crucial expression of that which distinguishes an actually human soul from the kind of mere opinion which is found among the beasts which we may have adopted as household pets. Thus, as I shall show in this reflection on my own experience, Leibniz did not exaggerate, either in placing the importance which he did on the role of the conception of the *Monadology*, or in denouncing the incompetence of the method of Sophistry employed by Descartes and by such followers of Descartes as the so-called Newtonians.¹¹

The Ancient Roots of Modern Science

However, that cited discovery by Cusa was not unique to his time. It had been the same underlying principle inherent in the work of the Pythagoreans (*Sphaerics*), and, beyond that, in the earlier development of the role of astrogration in relatively successful forms of those cultures of "The Peoples of the Sea" who had expressed the most developed type of human culture emerging in a Mediterranean region coming out of the time of the great glacial melt of about 21,000 or so years ago.

So, despite the fact of some progress, prior to that of the mid-Fifteenth Century European Renaissance, all modern progress in science has depended on those aspects of science and its cultural relatives which existed prior to the deaths of Eratosthenes and Archimedes, and prior to that darkened and dismal period of European history under the Roman and Byzantine empires, and the evils of a medieval society brutishly corrupted by the partnership of Venetian usury and Norman chivalry. Such is the conclusion which is required to be drawn from the internal evidence of physical science viewed from the standpoint of Cusa and his proper followers. This is that which Cusa led in presenting, as in the exemplary instance of his *De Docta Ignorantia*. Cusa's work was a resuscitation of what had been, over what must have seemed nearly two millennia¹² the nearly suffocated impulse of scientific progress. His role was, in this fashion, the resuscitation of the long misplaced legacy of the Pythagoreans and Plato.

Notably, the very idea of "universal" depends, ontologically, on the view of the progress of human life on Earth as an extension of discovery of what is, scientifically, experimentally valid knowledge of the astral universe: *not the other way*

11. Cf. Leibniz vs. Clarke (1715-1716).

12. Since approximately 200 B.C.

around. In the same way, the history of the development of the civilization spawned in the region of the Mediterranean, flows upriver from the ocean and seas, not down-river.¹³

Since that emergence of the approximately well known forms of civilization since the formation of the alliance among Egypt (e.g., Cyrenaica), the Ionians, and the Etruscans, against the predatory maritime power of Tyre, all of the net progress of European civilization (also, since development which had occurred earlier than that time, in particular), has been a reflection of a naturally, uniquely human way of thinking about scientific, and related Classical-artistic principles of discovery and its practice for which the achievements of the so-called Pythagoreans represent a typical bench-mark.

The existence of long periods of stagnation, and even retrogressions in human culture, has been chiefly, either unfavorable natural conditions in some or much of the Biosphere, or cultural degeneracy. Cases of cultural degeneracy include, typically, periods of relative degeneracy under widespread practice of slavery, or serfdom, or under modes of degeneracy such as those of the post-1945 spread of a new mode in Sophistry in Europe and the Americas, as the latter have been spread, especially, since the rise of the virtual trend toward a “new dark age” inhering in the influence of the so-called “68ers” in the Americas and Europe.

The Importance of Leibniz

The discoverer of modern science, after a long dark age before his own birth c. 1401 A.D., was, as I have emphasized, again, above, the Nicholas of Cusa followed in science, most notably, as Kepler emphasized, by Luca Pacioli’s protegee

13. There is a relevant, stunning sense of validity about the first chapter of *Genesis* on this account. Although the imagery of that chapter is largely poetic, if we avoid the temptation of brutishly ignorant people (including scientifically simple-minded theologians), and if we read that poetic chapter as key to gaining a *prosaic* conception of creation, it is a scientifically validated, *poetic* account of the relationship of the existence of the universe to the origins of, and development of Earth, up through the point of the emergence of the existence of the implicitly assigned role of the human species. The correct order is consistent with the viewpoint defined by millennia of development of an astro-navigating, transoceanic culture of a “people of the sea.”

If one discards the usual classroom babble about such matters, we are confronted with the fact, that the concept of “universal” congruent with the notion of *Sphaerics* among the Pythagoreans and Plato, were possible as a physical concept, only from the standpoint of many thousands of years of astro-navigation by a migratory culture of a “peoples of the sea.” (It were better to avoid those portions of the so-called “Old Testament” which are clearly traced, as I recognized from some intensive 1950s study of some relevant ancient Mesopotamian archeology, to the Mesopotamian pagan myths known to have been imposed as pagan redactions of, and syncretic insertions into Hebrew texts, as by the scribes of Jewish captives by such captors as the Babylonian and Achaemenid forms of imperial tyrannies.) Moses reflects the maritime influence of “The Peoples of the Sea” on the origins of the culture of ancient Egypt, not “down-river,” not the discovery of a virtually land-locked culture, but the knowledge gained from navigation of the seas. For comparison, the settlement of Sumer was a colony of a non-Semitic, Indian-Ocean based maritime culture.

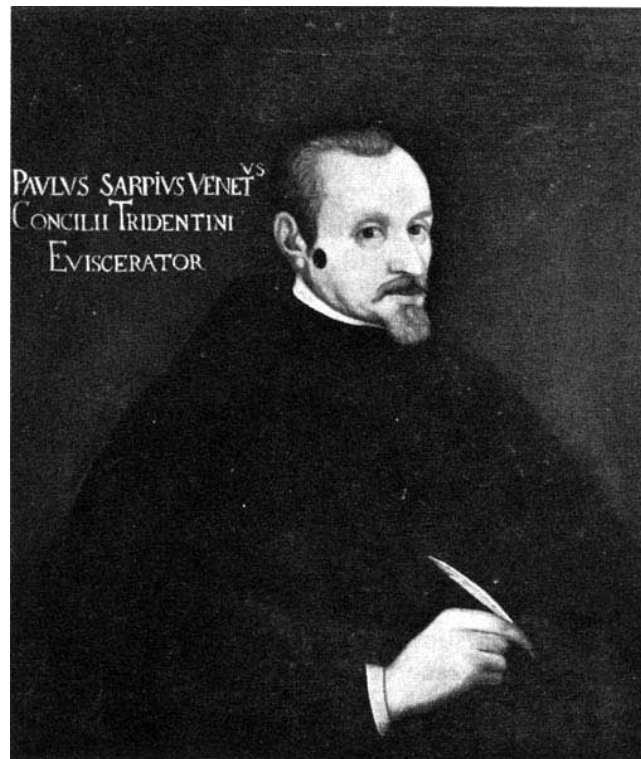

Venice’s Paolo Sarpi (1552-1623) organized the cult of axiomatic empiricism in modern science. His influence remains pervasive today, as scientists achieve important results in the laboratory, but are often reduced to impotence by “the mere presence of a peer-review blackboard.”

Leonardo da Vinci; but the realization of a truly universal applied science as had been intended by Cusa, was accomplished by the Kepler who, as I shall clarify this in the later pages of this present report, first gave modern science a practicable, scientific conception of the astrophysical universe. After Kepler and Fermat, the central, most important, and indispensable figure of all modern science, until the work of such among Leibniz’s own successors such as Gauss, Dirichlet, and Riemann, was Gottfried Leibniz.

It was Kepler whose uniquely original discovery of the physical meaning of *universal* had distinguished him, absolutely, as a scientist, contrary to the fraud of Claudius Ptolemy, and contrary to the failure by Copernicus and Brahe to discover the relevant, central principle of astrophysics, which made possible all competent science which has been developed after Kepler’s own work.

Admittedly, there are many qualified working physicists who were (and, still are) not only competent in even their relatively limited fashion, and whose contributions have been indispensable for some progress, even some crucial progress, despite the insistence by many among them, on reconciling their outlook with some form of defense of the hoaxster Isaac Newton. In some time, I have been associated with a number of most notable and less notable such among my own contem-

poraries most of whom are deceased today.

However, unfortunately, the influence of the modern European form of Sophistry, the systemic influence of a *Liberalism*, such as that of the empiricist followers of Galileo and Descartes, an empiricism which had been launched by Paolo Sarpi, has organized the modern empiricist cult within the ranks of science, a replacement of scientific experimental methods by a “revealed-religion-style” cult of merely axiomatic empiricism, a cult which has been faithfully derived from such ancient influences as Euclid and Claudius Ptolemy, but a cult packaged within an arrangement of its own.

The influence of the corruption represented by this cult of modern Liberalism has created the ironical situation in which working scientists achieving crucial results in the laboratory, are often reduced to impotence by even the mere presence of a peer-review blackboard, or by a kindred ritual of modern science’s borrowings from a Babylonian high priesthood.¹⁴

When I write *Liberalism* here, I mean the dogma, prevalent in the frankly decadent European culture of today, which Paolo Sarpi and his mafia-like gambling expert, Galileo, premised on their revival of the argument of the medieval irrationalist William of Ockham. Sarpi and Galileo limited scientific workers (and others) to the privilege of uncovering merely “practical” knowledge of scientific-like practices, and, as the empiricists have done, to reduce and degrade that experimental knowledge to mere mathematical formulations of a genre consistent with digital methods. Like the Olympian Zeus of Aeschylus’ *Prometheus Bound*, the empiricist dogma forbids the modern scientist (or, others) to deliver knowledge of the principle of “fire” as practical knowledge of the society in general.¹⁵ Thus, the dying out of the influ-



White House photo/David Bohrer
*High Priestess of Anglo-Dutch Liberalism
Lynne Cheney, the U.S. Vice President's
controller, runs a campus gestapo operation to
silence opposition to the Bush-Cheney
Administration's policies.*



swiss-image.ch/Remy Steinegger
*Baby Boomer Al Gore's zero-growth universe—
unlike the actual, anti-entropic universe—only
runs down, and needs to be periodically wound
up again. Gore is shown here at the World
Economic Forum, Jan. 24, 2008*

ence of the generation which made possible the U.S.A.’s original Moon landing, has produced a generation, like that of the followers of the Prince of Wales’ fat-headed dupe, the former U.S. Vice-President Al Gore, whose abhorrence or avoidance of scientific principles has utterly crippled both science and economy since the rise of the influence of today’s “Baby Boomers”¹⁶ has replaced the relative competence of the earlier generations.

Anglo-Dutch Liberalism, the only variety of religious belief to which the modern European civilization’s Sophist is truly faithful, in or out of places of religious worship, is cultivated by those academic and related high priesthods¹⁷ whose altars of human mind-sacrificing practices have been, traditionally, the blackboard and the mumbo-jumbo, reductionist theology of the peer-review journals. It is the Aristotelean heritage of the digital gobbledegook of Euclidean geometry, which has been substituted for physical science, all over again,

14. The spread of the fraud of “Global Warming,” is a relevant example of that sort of brainwashing of even otherwise intelligent people.

15. The present-day lunatic opponent of nuclear power is in the brutish tradition of not only the Malthusians, but the ancient Delphic cult of Apollo-Dionysus. The brainwashed stratum of ideologically “white-collar,” “Organization Man” Liberals born, on both sides of the Atlantic between 1945-1958, typifies the mad 68ers who have played an essential role in the destruction of globally extended European civilization since 1968.

16. The “white collar” breed of “68ers” spawned by “white collar” suburbia and kindred precincts during the 1945-1958 interval, in Europe and the Americas.

17. Such as the types of influential degenerates associated with the role exerted on campuses by Mrs. Lynne Cheney and the Senator Lieberman who was almost created out of Connecticut mud by the family of William F. Buckley, Jr.

as it was done in the case of the exemplary, willfully fraudulent, Roman imperial neo-Aristotelean Sophistry of Claudius Ptolemy.

In the course of Europe's Seventeenth Century, the mantle of the hoaxsters Galileo, Sir Francis Bacon, and Thomas Hobbes, was passed to figures such as Hooke, and to the thoroughly evil English organizer of the African slave-trade, John Locke, and to Rene Descartes.

Against that hostile-to-science background of Liberal superstitions, Leibniz made two outstanding, principled achievements in his defense of the fundamental principle of a competent modern science. The first of these two achievements was Leibniz's uniquely original discovery of the Keplerian infinitesimal calculus, the only competent calculus, as opposed to the arbitrary dogma of de Moivre, D'Alembert, Euler, Lagrange, Laplace, Cauchy, et al.; the second was his restoration of the ancient Pythagorean-Platonic principle of *dynamis* under the modern name of *dynamics*. These two discoveries by Leibniz, which lead to the intrinsically non-linear (e.g., non-digital), universal physical principle of *least action*, have the still deeper, fundamental importance, of re-establishing that notion of *universal* embedded in the work of the Pythagoreans and Plato: the universe reflected in the work of the ancient maritime cultures from which the Pythagorean science of Sphaerics was derived, and the universe of astrophysics as defined by Kepler.¹⁸

Thus, for a competent science today, there is no scientific meaning of the term "infinitesimal" except that defined both by Kepler for the Earth orbit which can not be defined by the methods of quadrature used by Archimedes, and defined as Leibniz also uses the same concept in defining the ontological, rather than Cartesian meaning of the term "infinitesimal." It is the latter alternative which must be defined in these pages.

What we must intend to mean by science, is experimentally premised knowledge derived from the conception of the universe as Kepler's discoveries in Astrophysics first defined the only valid modern physical meaning of the term universe itself. Kepler defined the universe as a principle. Kepler's importance on that specific account, is absolutely crucial for all competent approaches to an urgently needed re-examination of the prevalent presumptions of modern science today.

18. Although the principle of the catenary (or, "funicular") was known, and employed (for the construction of the cupola of Santa Maria del Fiore), by Filippo Brunelleschi, none of the modern Sophists, including Galileo, notably, has understood the universal physical principle involved. This exclusion includes willful hoaxsters such as Leonhard Euler, and mere incompetents proliferating among Euler's empiricist allies and followers, such as Laplace, Cauchy, Clausius, and Grassmann. The attack, by the hoaxsters Leonhard Euler, et al., on Leibniz's concept of the ontologically infinitesimal, was implicitly devastated by the 1799 doctoral dissertation of the Carl F. Gauss who later identified his argument as the proper representation of The Fundamental Theorem of Algebra.

2. Riemann's Universe

The significance of Leibniz's use of the notion of *dynamics*, can not be made fully clear until we have proceeded from comprehension of the implications of Riemann's own 1854 habilitation dissertation.¹⁹ As Riemann emphasizes in the opening paragraphs of that 1854 dissertation, it was not until



Bernhard Riemann

his own founding of a modern anti-Euclidean physical geometry, that modern science had delivered such an explicitly direct, and systemically effective assault on the relatively vast, fraudulent tradition of Euclidean geometry.²⁰

Today, since the work of Academician V.I. Vernadsky and Albert Einstein, the revolutions in physical science accomplished by that pair, have established the practical implications of Riemann's

revolutionary accomplishments to such a degree, that it would be childish not to look at the fruits of Riemann's genius in the light of the work of those two magnificent successors, as I do, once again, here.²¹

Some prefatory observations, as follow here immediately, are required before plunging directly into the implications of the combined work of Vernadsky and Einstein.

The emergence of modern atomic and nuclear physics since the work of great pioneers such as Max Planck, has compelled serious thinkers to consider a freshly presented kind of evidence respecting the nature, and extent of the reality which modern academic and comparable opinion had been accustomed to treat as the experimental basis for progress in physical science. On this account, the fraudulent and savage attack on Planck, within 1914-1917 Germany and Austria, by the followers of both the crudely mystical Ernst Mach and the implicitly criminal Bertrand Russell, has tended to obscure the deeper ontological implications of Planck's discovery. The most essential of the issues so posed against Planck's work and outlook, by the increasingly radical positivist gangs, was not really a new issue; it was the

19. Op. cit.

20. Implicitly, Cusa, Kepler, Fermat, and Leibniz had rejected the Euclidean tradition, but, since they worked under the deadly threat of continued expressions of the Inquisition, they did so only by indirection. The medieval Inquisition had hated the hoaxster Galileo, but that was the reflection of an internal Venetian quarrel over the struggle for political and financial power, between the old Venetian partisans of Claudius Ptolemy and the new Venetian party of Paolo Sarpi.

21. Cf. Lyndon H. LaRouche, Jr. "Vernadsky & Dirichlet's Principle," *EIR*, June 3, 2005.

Ioannis Kepleri
**HARMONICES
MVNDI**
LIBRI V. QVORVM

- **INTRO**
- Technical Advice
- Acknowledgments
- Archives
- Contact
- **BOOK I**
- ▲ **BOOK II**
- **BOOK III**
- ◆ **BOOK IV**
- ◇ **BOOK V**



wlym.com

Johannes Kepler (1571-1630) gave modern science its first practicable, scientific conception of the astronomical universe. The illustrations here are from the LaRouche Youth Movement's "Basement" project on Kepler's Harmony of the World; the LYM explicates this monumental work through the use of animated graphics and musical examples (www.wlym.com/~animations).

The drawing is from Kepler's frontispiece to his 1627 Rudolphine Tables. It shows Copernicus and Tycho Brahe at the center; while Hipparchus and Ptolemy look on. On the base, the panel to the left shows Kepler himself, laboring by candlelight.

The musical scales shown here are taken from Kepler's Harmony, and show the "tonalities" of the harmonic orbits of the planets (these can be heard on the website). Above is the major scale; below is the minor scale.

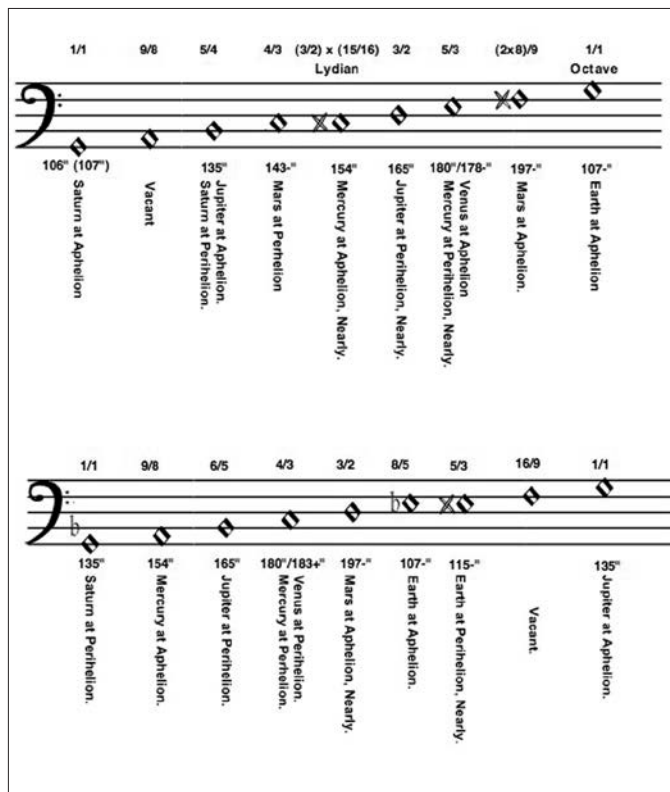

same issue of method already posed by Kepler's harmonical study of the Solar System, but an issue whose attention had been transferred from the astronomical, to the microphysical domain.

The issue, in both cases, is the issue of sense-certainty.

Months before that moment we are, so to speak, born as if "taken fresh out of the manufacturer's box," we are already equipped with sense-organs whose function is specific to our biological organization as living organisms. We do not actually know the universe outside us through a literal reading of those sensations; what we know about those experiences is the practical evidence to the effect that we are able to know that we are experiencing, not the universe itself directly, but, rather, the raw effect of the actions of the outside world, upon those sense-organs.

The commonplace, naive and negligent, overreaching quality of misinterpretation of the results of that arrangement, becomes the proper experimental subject of our critical faculties, once our attention is shifted from the local space-time we inhabit, to the phenomena experienced, as Riemann emphasized, in study of the relative extremes of the ancient mariner's astronomical, the very large ("the infinite"), and the modern microphysical ("the infinitesimal").²²

Thus, careless opinion, whether among scientists or others, tends to favor the visual sense naively, as the childish Sophistry of Euclid treated this as *a priori* reality for geometry. Thus, when we attempt to reconcile supposed, Euclidean "sense-certainty" with the physical composition of the Solar System in the large, we also encounter phenomena which, as Kepler emphasized, behave in a manner otherwise also specific to

22. Op. cit.

the sense-faculty of hearing (“harmonics”). Kepler’s discovery of a quantitative expression for a general principle of gravitation, rested upon a recognition of that ironical relationship among the two senses which arises when we attempt to extend the habits of local opinion to the astronomical scale. Max Planck confronted us with a kindred type of paradox, in confronting the delusions of sense-certainty in respect to matters bordering upon, or in the domain of the sub-atomic.

For example, the simple-minded view of sub-atomic microspace taught *at me* in schools and university, and other settings, is that it was demanded that I believe in the universe of an empty space within which sub-atomic particles and other critters had been dumped to roam. That pathetic view of the matter should be scrutinized from the standpoint of reference to Kepler’s discovery of the measurement of the principle of astronomical gravitation. Both extremes, those of astrophysics and microphysics, are to be viewed as Riemann warned (already) in his habilitation dissertation. In both cases, Kepler’s Solar System, and the micro-physical space explored implicitly by Max Planck, we are dealing, here and now, with a *specifically Riemannian* challenge to the notions of simply extended sense-perception.

On the level of sub-atomic microspace, we are operating, not with our raw senses as such, but with instruments which we usually employ mistakenly, as if they were extensions of simple sense-perception, and therefore might be treated as the dupes of Euclid regard the crude evidence of ordinary sense-perception. If we return our gaze to the case made by Kepler for the systemic physical, functional organization of the Solar System, and regard both cases as Riemann warned us in regard to relative extremes of scale, the hysterical nature of the fraud expressed for particle microphysics by the essential argument of Planck’s and Einstein’s opponents, or that argument’s statistical or statistical-like substitutes, becomes immediately visible.

The lesson here, is that the fact that the phenomena reported are real descriptions of real *phenomena*, does not mean that the actual source of the adumbrated phenomena has been rightly adduced. The fact that the cat eats Wheaties with sugar and milk, would not make the cat human.

The paradox which I have just, thus described, impels a careful thinker to recognize that our senses are merely instrumentation, as we apply instruments as substitutes for sense-perception in imagining the events attributed to the micro-physical domain. This warns us to abandon the customary faith in sense-certainty entirely, that to such effect that we separate the idea of efficiently knowing from attributing a literal meaning to the evidence transmitted to us through our biological sense-perceptual apparatus. The task thus presented to us, is to distinguish the issue of the validity of *knowing* (an act of the human mind) from the qualitatively different issue of the validity of *sense-perceptual experience as such* (an observed action of the biological sense-apparatus).

It should be obvious, from the qualitative superiority of the human mind over the simpler capabilities of the beasts, that efficient forms of human knowledge are not located in those qualities of sense-perceptual faculties characteristic of the beasts,

The Matter of Prometheus

This impels the wise to take a step further on this same account. On this account, science, as known to the ancient Pythagoreans and Plato, or to the modern Kepler, Fermat, Leibniz, and Riemann, is defined, not by statistical methods, but by a qualitatively ontological distinction between universal physical principles and the mere experiencing of particular events: the same quality of distinction which Cusa follower Kepler made between the *analog-like* principle which governs the planetary orbit, and the *digital tracking* of the body following that orbital pathway. That is the difference which exposes Leonhard Euler’s argument against Leibniz’s infinitesimal as a piece of very foolish, childish rage. Contrary to the hoax intentionally perpetrated by Leonhard Euler, the Leibniz-Bernoulli infinitesimal of physical least action, is not a statistical (e.g., *digital*) quantity of space, but an *analog* principle which exists and acts, ontologically, as the expression of an “infinitely” universal principle of universal action.²³

The difference expressed so, is the distinction between a real existence (a universal physical principle, such as the principle of gravitation discovered by Kepler) and a local shadow of the effect of that existence (the effect of the observed action of that principle as detectable as adumbrated within the scope of any smallest distance of displacement chosen).

So, the fool who is duped by Euler et al., presumes implicitly, that gravitation is an effect produced (as if inductively) by the measured action between two points in a pathway in Cartesian (e.g., Euclidean) space-time, rather than the action being embedded in the universal physical space which is to be recognized as the author of the apparent phenomenon of gravitation. That folly which I have identified thus, is characteristic of the (deductive-inductive) ideological world-outlook of not only Aristotle and Euclid, but also the followers of Sarpi’s Ockhamite, so-called “Lib-

23. Those who wish to quarrel with the point I make here, should improve themselves by clinical reference to the pathetic suggestion to D’Alembert by de Moivre, that the mathematical “infinitesimals” they encountered in cubic and biquadratic roots of algebraic functions, should be overlooked, arbitrarily, as being inconvenient evidence for the case they were arguing, and, on those tendentious grounds alone, must be considered as patently only imaginary diversions, as if they might have been induced by some malicious deceiver lurking under the floorboards of reality. The actual absurdity of that kind of bald lying and irrationalism by de Moivre and D’Alembert, did not prevent Euler, Lagrange, Laplace, Cauchy, Clausius, and Grassmann, et al., from perpetrating the same essential folly against both modern physical science and the cause of reason itself. Cf. Sky Shields, “What Exactly, Is a Human Being? Analog, Digital, and Transcendental,” *EIR*, Jan. 4, 2008.



The M81 galaxy (a composite of photos taken from three telescopes). Imagine how “a fast-spinning, bumptious young Sun, spun off some of its material in a plane around it, a plane of plasma subjected to (almost certainly) polarized Solar radiation impacting the plasma,” which then condensed into the planets and moons of our Solar System.

eral” irrationalism.

This issue of method takes us back, directly, to the issue of Aeschylus’ *Prometheus Bound*. The term “fire” in that drama, signifies human knowledge of efficient universal physical principles, each and all subsumed under the description of an effect which is also named, among other appropriate terms of description, as “fire.” It signifies, as Heraclitus’ aphorism does, continuous universal principles of universal action, as distinct from discrete events, as this distinction is emphasized by Plato’s *Parmenides* dialogue. The ancient mariner of maritime cultures, looking up to the sky, saw the reflection of man living under a starry universe, and learned, thus, to navigate the oceans and seas under what appeared to him, in his role as a great navigator, as the law under which his destination was arranged.

However, as such great navigators of the distant past discovered, and reflected this discovery in the calendars which they constructed, the observed starry universe was not fixed, but constantly changing. This is the notion of universe which must be adopted for science, as only the maritime cultures could have developed such knowledge of systemic change over relevant long passages of time, over many successive generations. This knowledge is presented to us in studies of relevant, surviving features of ancient calendars. This is the characteristic expression of the Py-

thagorean science called *Sphaerics*.

The result of such developments within long reaches of continuing forms of maritime cultures, and the extension of this experience of maritime cultures to inland settlements, has been the emergence of *the conception of universal principles of change*, or what is to be regarded as science today. The role of the metaphor “fire” in Aeschylus’ *Prometheus Bound*, has that significance.

The universe is ruled by great principles, but those principles are the children of the still greater principles of universal changes. It is the latter, higher order of change which defines the notion of a valid form of universal science. It is the notion of a universe defined, ontologically, by this higher principle of universal change, which constitutes a valid science, which defines the meaning of the “fire” in *Prometheus Bound*.

The Implications for Einstein

The crucial point posed by these considerations was summed up by Einstein as the concept of a finite, but also self-bounded universe. This expressed view by Einstein et al., signifies that the universe is composed, primarily, ontologically, of universal principles, and that particular events are products of the local interactions of these principles. Thus, for Einstein, the universe is finite, that in the sense that

it is self-bounded by its own universal physical principles; it has the measure of “one,” and is therefore, since so self-bounded, finite.

The matter does not end with that argument by Einstein and others. We come, bump, up against a second major presumption: the silly presumption that the universe is fixed, unless something outside it moves it. The very “history” of the Solar System contradicts the assumption of the “fixed universe.” A fast-spinning, more bumptious young Sun, spun off some of its material in a plane around it, a plane of plasma subjected to (almost certainly) polarized Solar radiation impacting the plasma, and thus generating a process of fusion which produced the known standard elements and isotopes of the known Solar System’s Mendeleev table. From this plasma, lawful planetary pathways were infested with the products of that plasma, and, according to Gauss’s argument on this point, the distributed stuff was condensed into planets and moons.

So, today, on the same general account as that, the weather experienced on Earth is influenced significantly by “cosmic” radiation from the Crab Nebula, radiation which interacts with Solar radiation, to effect conditions thus experienced on the surface of our Earth.

On what authority might anyone presume to assume that that universe can do nothing without “outside” prompting? Philo (Judaeus) of Alexandria posed a similar challenge to what he held in contempt as the Aristoteleans of the lifetime of the original Christian Apostles. Can we presume that once a Creator had created a universe, someone else (perhaps a Gnostic such as Satan) must wind the universe up (or, perhaps, down) for Isaac Newton’s amusement, from time-to-time? Contrary to such possible challenges, the evidence is that the essential character of the universe’s trajectory is its motion: that quality of motion is the essence of existence in our universe. That is to say, that the action of gravitation in, for example, the Solar orbit is action *per se*, creative action expressed in effect as motion. It is the existence of that *anti-entropic* action itself which is experienced as *the infinitesimal* in a Kepler-Riemann-Einstein map of the universe.

3. Vernadsky & the Living Mind

I have received no credible report which indicates that his discoveries in chemistry led Louis Pasteur to claim that he had defined a universal physical principle of life; but, nonetheless, his discoveries in chemistry set the stage for what the later work of Academician V.I. Vernadsky was the first to define as that relevant, specific kind of apparent chemical principle of the D.I. Mendeleev Periodic Table of chemistry. This principle expressed in practice the absolute *ontological* distinction of the products of living pro-

cesses from those characteristic of the domain of the chemistry of non-living processes.²⁴

The crucial aspect of that discovery by Vernadsky, was, in the first instance, his concept of the *Biosphere*. What was crucial on this account, was his attention to the fossil “history” of the Earth’s outer crust, including the character of the atmosphere and the general supply of water as products of the *Biosphere*. The increase of the ratio of the mass of living processes and their specific fossils to the abiotic mass, demonstrated, and that in a crucial way, that life is in the process of transforming our planet from an abiotic state, toward being, increasingly, the mass of living process—up to some possibly conceivable, undetermined limit within the bounds of our planet.²⁵



Vladimir I. Vernadsky

However, that world is not only becoming, more and more, a biotic mass, but also the growing mass of the *Noösphere*: the latter a product which is not found otherwise among living processes. That *Noösphere*’s included characteristic is one of the requirements of the increasing role, and increasing mass of physical product generated by the unique action of the *intended* increase of the typical human individual’s creative intelligence.

Thus, in a sense of things which is, at first glance, apparently similar to the distinction of living from non-living processes, Vernadsky’s adoption of the extant term *Noösphere*, identifying a concept (*noësis*) unique to his own discovery of this principle of geochemistry, was a product of principles beyond those of the actually living chemistry. These were principles differing from, and categorically external to those which he had applied to define the subject of the *Biosphere*. In this case, his relevant measurement was to compare the increasing mass of products of rate of increase of products of human creative-productive activity, to the relative masses of both the abiotic domain and *Biosphere*.

The measurement of the role of the *Noösphere*, required measuring, at least implicitly, *both* the estimated potential relative population-density of the human population (as contrasted with animal ecologies), and the mass of physical product per unit of relative potential population-density. This

24. There is no known case in which the concept of a *Biosphere* or *Noösphere* has been competently proposed, or presented scientifically, except that of Russia’s Academician V.I. Vernadsky’s reliance on experimental principles of physical chemistry.

25. LaRouche, *op. cit.*

distinction is expressed in what I have adopted as a needed scientific revolution, a revolution rooted largely in the discoveries of Bernhard Riemann, a revolution in the domain of nations' physical-economic practice.

The effect of these measurements, has been to illustrate two points. *First*, that the principle of life is distinct from the principles of non-life; *second*, that the cognitive powers of the human mind reflect a specific potency of the developed human mind, which is akin to the general notion of harmonic resonance, but which is specifically absent in the adducible brain functions of all lower forms of life. I explain this distinction and its implications.

My own modification in the conception of a science of economy, which I have introduced in treating these accomplishments made by Vernadsky, has been to emphasize, as I have written here earlier, that the distinction of the human mind from that of all lower forms of life, is that the human mind is "tuned" to an effectively physical factor of "universal creativity" which is absent in all lower forms of life, including the higher apes in the category of the lower, sub-human order of living creatures. However, this human faculty is transmissible among individuals within society, as a quality of being which is, in effect, historically immortal: immortal with respect to the mortality of the human living organism otherwise. This is what I have identified earlier here as the element of *supra-bi-otic immortality* in the quality of man and woman as identified in *Genesis* 1.²⁶

Whatever the life's span of the creative individual, there is no doubt of the greater range of benefit which the truly creative intellect, such as that of a Cusa, Kepler, Fermat, Leibniz,



The great 18th-Century scholar Moses Mendelssohn (top right)—known as the Socrates of Berlin—among his other accomplishments, designed the educational program for military professionals used by Graf Wilhelm von Schaumburg-Lippe von Schaumburg (above). One of the products of this program was Lt. Gen. Gerhard von Scharnhorst (right), hero of Germany's wars against Napoleon.



Moses Mendelssohn, Friedrich Schiller, Lazare Carnot, the von Humboldt brothers, Gauss, Riemann, Planck, Vernadsky, Einstein, or what great U.S. hero-Presidents such as Abraham Lincoln and Franklin Roosevelt contributed, in the course of burning the life-candle of each among them to the end of effecting the advancement of what physical chemist Vernadsky defines as the Noösphere. Those individuals may die, but their creative work itself, like the paintings of Leonardo da Vinci, Raphael Sanzio, and Rembrandt, is not inherently perishable in that same way as their living human body. A valid universal physical principle, once discovered, has the characteristics of a probably immortal action.

The Immortal Soul

The copy of what has become a presently very rare book, a copy which has been in my possession for a number of years, *Moses Mendelssohn, Sein Leben und Seine Werke*,

26. The question implied is: to what degree is the intellectually developed and active mind a factor of inherent relative advantage in promoting longevity? Even as evil, but active a mind as that of the virtually Satanic Bertrand Russell, implies such a question. The conclusion is, in any case, were this to prove speculation, or not, it were prudent to think as profoundly as if one thought one's life depended upon it, whatever the actual outcome in any particular case. Were it not wiser, in any event, to be in tune with the highest ranking existence in our universe?

by Dr. M. Kayserling (Leipzig: Herman Mendelssohn, 1862), is packed with a carefully assembled amount of anecdotal material, material which affords a concise summation of certain relatively crucial, added insights into both the personality of Moses Mendelssohn and his historical significance.

Notable among the rarely considered, but historically crucial aspects of his life's accomplishment, is the example of what he describes in a passage from a letter, a passage which I have translated simply into English here, concerning the identification by Mendelssohn of what he describes simply as a remarkable "personal acquaintance with the great Prince of a small German state, Graf Wilhelm von Schaumburg-Lippe.... An excellent Greek soul in a rough Westphalian body." As other documents have shown, it was out of this association between the two, that Mendelssohn designed the educational program used by Graf Wilhelm, one of the most brilliantly accomplished military strategists of his time, for the education of military professionals, including among the institution's most notable students, the great Scharnhorst.

The German Jew was thus, in this exemplary fashion of Moses Mendelssohn, and related ways, an essential, integral part of the rise of German national culture, and European culture more broadly, that to such a degree that the mass-murder of German Jews by the Hitler regime installed by, chiefly, Anglo-American financiers, a murder almost to the point of extinction, was an attempted murder of the soul of Germany itself. It is culture, not biological "race," which defines a true nation in functional terms. All human beings not damaged in their essential biological potentials share the same principle of human creativity. The differences lie in the type of the culture, and the degree of development of the individual's potential. Great cultures are those which assimilate their own sources of enriched development, as German culture assimilated its great debt to Moses Mendelssohn's extended family.

To discover the actual Moses Mendelssohn who contributed this continuing effect, we must consider an effect reaching far beyond his own last illness and death, an effect brought about by that great heir of the tradition of the great Moses of Egypt, and explicitly and meaningfully the heir of Moses Maimonides. Thus, we must also situate him historically as he is actually situated for those among us who understand, still today.

We must locate him as situated in his crucial friendship with the Classical playwright Gotthold Lessing, who was the student and protege of the same great Eighteenth-Century mathematician and Classical scholar Abraham Kästner (1719-1800). Kästner was, in turn, from birth, a figure from Lessing's and Leibniz's home city of Leipzig, and born and raised there in the time of Johann Sebastian Bach's greatest work, about three years after the death of one of the greatest historical figures from there, Leibniz.

Among other contributions to civilization, Kästner had played a crucial role, as a leading intellect at Göttingen, in support of our Benjamin Franklin and the cause of American freedom, as also in promoting the life's work of Mendelssohn's collaborator Lessing.²⁷

The essence of the genius of Moses Mendelssohn, born a poor Jew from Dessau, is expressed most powerfully, and most significantly, in his greatest personal work, his great commentary on Plato, on the subject of the immortality of the individual human soul, the *Phaedon*. It is that work which I emphasize as relevant to the case I present within this present chapter of the report.

These geniuses to whom I have just referred, were among the typical personalities who exemplify that efficient immortality of the human personality which distinguishes the human person from the beasts. The aspect of the work of such truly creative personalities as those, is that which is specifically immortal. This immortal aspect lies in the replication of the mental action which generates, and regenerates truly creative (i.e., anti-entropic) contributions to promotion and defense of human progress. The mere action, as it might be manifest in the form of a mere thing, does not express the quality of immortality; creativity never occurs in the mode of deductive-inductive action, but only in the form of those analog and related modes typified by the act of discovery of a universal physical principle, the enhancement and promotion of that discovery as such. The uniquely original development of the concept of universal physical least action, by the collaboration of Leibniz with Jean Bernouilli, typifies such a creative mental action which changes the characteristics of mankind's physical world.

As Aeschylus outlines the case in his *Prometheus Bound*, the degrading of what were otherwise naturally human beings into the likeness of mere beasts, as the practice of helotry by the Delphi cult of Lycurgan Sparta did such evil, or the corruption spread as what became the Peloponnesian War by Delphic "Liberalism" (Sophistry), in Pericles' Athens, is effected by some means such as the ancient spread of the Sophistry in the form of Euclidean ideology. It was the Sophistry of Euclidean geometry which "rephrased" the geometry of the Pythagoreans and Plato's other circles, that to the effect of removing the soul from it, transforming it into a Sophist's mere dangling, dead, deductive "thing."

This distinction of the intellectual powers whose expression distinguishes the truly free man from either the dutiful or insolent slave, is human individual creativity. That creativity is

27. Kästner, early in his adult life, had dedicated his life's mission to defending the work of the two greatest of the citizens from that home city of Leipzig, Gottfried Leibniz and Johann Sebastian Bach. Naturally, none of that degenerate tribe known as the 18th and early 19th centuries' Romantics liked any true reading of the work of Leibniz, Bach, or Lessing.



Creativity is that which differentiates man from the beasts, as reflected here in Albrecht Dürer's engraving "St. Jerome in His Study." The lion stands guard to protect the man, who is busy translating the Bible into Latin.

that aspect of the deceased person which persists in the form of the expression of that which promotes the continuing creative progress of the human species, that in ways implicit in *Genesis* 1's distinction of the man and woman from the beast.

Since the animal aspect of each of us must ultimately die like a dog, the nature of the man or woman who is free in his or her self, is that which is expressed by what the Apostles John and Paul emphasize as *agapē*,²⁸ or, as the Peace of Westphalia's expression of this, as "the benefit of the other." Our efficient immortality lives in that which is appropriately human, as defined in this fashion, which we give to others, and

28. E.g., Paul in *I Corinthians* 13.

to society generally. By giving, so, we avoid losing the desirable meaning of our mortal existence. In this way, we may triumph over the death of the mortal body which our true self inhabits during a moment of history. What this practice must give, essentially, is the development of the human powers of ourselves and the other person alike; but, on that very account, we must promote the general conditions of individual and social life on which the society's realization of creative ideas depends.

We must cease the regrettable habit of thinking of the needs of society, and of the needs of other men and women as we might think of the needs of pet dogs; we must think of other persons as essentially human beings, and think in terms of what that essential quality of the human being requires to fulfill the creative intention which is characteristic of its higher given nature.

Morality & Physical Science

We must acknowledge, as good scientists must, that there is no empty space in our universe. All physical doctrine which seeks to interpret physical space-time as a matter of action-at-a-distance, as between objects appearing as the singularities inhabiting space, is a belief trapped within an error which has been produced by a mere, actually unproven, arbitrary presumption. By defending that mere assumption, *apriori*, without experimental proof, as the believers in the Sophists Euclid or Newton do, the believers in such dogmas have created for themselves the delusions associated with a certain idea of infinite space. Thus, the idea of space as "infinitely" extended, as if in some linear fashion, is essentially, childishly absurd, infantile,

the world-outlook of one who has not really graduated from the womb, and therefore tends toward egg-centric types of imagined world-outlook.

The universe, however large it may appear to us, is finite, precisely in the way which Einstein argued, and as I have summarized that point earlier in this report.

The correction of the popularized, implicitly infantile error of sense-certainty, causes a certain sense of pain, or worse, in those who had been the true believers in the like of some piece of childish witchcraft akin to "Harry Potter," a folly in the likeness of that Lucifer worship (of the Lucis cult) fashioned by Aleister Crowley, the crony of H.G. Wells and Bertrand Russell.

On account of such beliefs, there is a certain, prevailing madness pervading the world's current varieties of popular opinions. On careful examination, these beliefs have found their roots in the societies' generalized, practical view of itself as a variety of animal life. Modern societies have risen culturally above the most simplistic versions of such beliefs, but the underlying assumptions associated with more or less blind faith in sense-certainties, are still a controlling factor among most of the members of these societies.

It is those kinds of popularized assumptions, which, as the expression of blind greed illustrates the point, prevent most among us, still today, from grasping the reality of the actual existence of the human soul. Many pretend to be religious, but only as gamblers hope, often religiously, for good luck at the gaming tables or in financial markets. The certainty of human immortality, as an achievable goal, escapes them. Their difficulty on this account is, ultimately, ontological; they have failed to accept our universe as it actually exists, and have created for themselves, in their child-like, even infantile fantasies, a belief in a non-existent universe from which, as Philo wrote on Aristotle, the concept of an actually efficient Creator is implicitly excluded.

The root of such conceptual problems as those, is a stubborn, more or less bestial quality of adherence to the notion of sense-certainty: like that of the famous preacher who, in the fashion of the barnyard rooster, created more souls among the ladies lured outside the tent, than were rescued from licentiousness during the services within.

The essential fault in those types of cases which I have only illustrated here, is expressed in forms which are essentially analogous to the virtual helotry of the citizen in today's cultures, one who clings to that delusion of sense-certainty which has been the belief promoted by the virtual established church, world wide, of Anglo-Dutch Liberal or comparable varieties of hedonism.

To free ourselves from such mental illnesses, we must locate our essential self in our practice of what the Peace of Westphalia defines as "the advantage of other" people, as of the other nation. It is the mutuality of that commitment among respectively sovereign cultures of peoples, which must become, now, the ordering of the relations among a system of what will be, respectively, perfectly sovereign nation-states. When we locate our personal interest in living there, in that fashion, we have taken a step of all humanity toward a sharing the intention of the true immortality of the human soul. As the Apostles John and Paul illustrate this for the followers of Jesus Christ, that is all that is essentially demanded of us, as individuals, in this life.

"Globalization," as proposed by the Jan. 19 Los Angeles event of the Rockefeller Foundation's Judith Rodin, in company with Governors Arnold Schwarzenegger and Ed Rendell, with Mayor Bloomberg, is a scheme for a new imperialism, a new Tower of Babel, a form of fascist imperialism, designed by the fascist Felix Rohatyn who played a culpable

role, with George Shultz, in the work of the Nazi-inspired Pinochet government of Chile, an echo of the Shultz-Rohatyn Pinochet project, whose establishment now would destroy the essential foundations of any civilized form of human life among the peoples of this planet.

4. The Principle of Creativity

It is the doctrine of *Genesis* 1, that the universe was created, and that man and woman are made in the image of the Creator. The most interesting, and paradoxical implication of the widespread recitation of that doctrine, is that virtually no professing Christian today actually *believes in practice*, that man and woman are made in the likeness of the Creator. Worse, most of them believe, at least implicitly, in terms of practice, that the Creator exists only as a kind of monarch, a kind of property owner who has somehow acquired a piece of super-galactic real estate which He chances to have received as the territory over which He might, at most, be permitted to reign.

For such people, *Genesis* 1 is merely a story told in deference to the presumption that any book must start somewhere.

If the God of *Genesis* 1 were actually the Creator of the universe, and man and woman were made in the Creator's likeness, and with comparable duties to perform on His behalf, why do men and women today, even scientists, think about the universe as they do? Why do they think as Philo rightly denounced Aristotle for doing? Why do they promote a bad fairy-tale, as Philo exposed Aristotle on this account, a silly fairy-tale according to which the Creator of the universe allegedly made himself permanently impotent by creating a perfect system?

Something is terribly wrong with the way in which such people seem to think! In fact, such wrong thinking is not only wrong, but evil in its consequences, just as the cult of Delphi propagated the evil real-estate magnate's style of the doctrine of Apollo-Dionysus.

The principal source of this prevalent error in belief, is the effect of the tradition typified by the case of *Prometheus Bound*: that the great majority of mankind has been mentally ensnared, like slaves, to the Olympian Zeus' prohibition against permitting mortal human beings to have knowledge of the principle of "fire." The matter of the issue which Philo raised in protest against the Gnostic Aristotelean dogma of his time, is typical of this: under the "law of universal entropy" even God the Creator is prohibited, according to that Aristotelean notion of law, from acting on the universe once the universe is created (thus, implicitly, awarding a free hand to the Satan otherwise appearing in the guise of Dostoyevsky's presentation of Tomas de Torquemada, "The Grand Inquisitor").

That doctrine attributed to the Olympian Zeus, implicitly prescribes a fixed, "zero growth" universe, like that of the



Creativity in the Renaissance: Geometer Luca Pacioli collaborated with Leonardo da Vinci, spreading the principle of modern science that originated with Nicholas of Cusa. Shown here, "Portrait of Fra Luca Pacioli and His Student," by Jacopo de'Barbari.

Roman Empire's lying Sophist Claudius Ptolemy, a universe in which development has ceased, and like the silly Isaac Newton's clock, or that of Prince of Wales Charles and his lackey Al Gore, only runs down, sadly in need of being wound up again.

The real universe, by contrast, is a process of endless creation, creation expressed in the form of both ceaseless motion and development—*anti-entropic development*. So, God the Creator is still alive, freed from Aristotle's Delphic prison, and still creating!

Those remarks with which I have opened this present, brief, concluding chapter of the report, correspond to well defined experimental types of universal physical principles. Kepler's uniquely original founding of modern astrophysical science is exemplary. The Leibniz infinitesimal is exemplary, contrary to the fraud perpetrated in common by such notables as Descartes, Newton, de Moivre, D'Alembert, Euler, Lagrange, Laplace, Cauchy, Clausius, Grassmann, et al., not to speak of such abysmal wretches as Mach, Bertrand Russell, et al.

Put most simply, the infinitesimal of the Leibniz calculus, which Leibniz derived from Kepler's discovery of universal gravitation, is, as I have stated this earlier in this report, an ontological, not an Aristotelean, Euclidean, or Cartesian infinitesimal. It is an expression of insurgent motion of physical development, an expression of an anti-en-

tropic universal principle. The quality of being infinitesimal originates in the relative scale of the action (in the case of Kepler's discovery) of that principle itself, as being relatively boundlessly universal and efficient (the *actual infinite*—infinite not in respect to its instantaneous current state, but its future development). This principle is expressed in the infinitesimal curvature of physical space-time at any instant.

In that sense of things, the universe is infinitely dense in its motion of change. The evidence that this sense of change is also associated with qualitative development in the universe, defines the principle of action in the universe as anti-entropic. A "law of entropy" is simply a fraud.

The creative powers of the individual human mind, as expressed in the human species' power to increase its potential relative population-density through means of the discovery of either universal physical principles as such, or their reflection, a power unique to the human species among all others, is our species' general distinction.

This and related considerations define the intrinsic nature of the human individual (when this knowledge of "fire" is not suppressed). Man, when true to his nature, acts anti-entropically upon the universe, not from underneath it, thus presenting himself (or, herself) in the likeness of the Creator from whom these powers of mankind are derived as they were gifts. The quality of action which mankind expresses in this assigned fashion, is intrinsically anti-entropic.

So, man and woman express a likeness to the Creator by acting, like the Creator's instrument, as a superior power upon the universe. In this, mankind's power progresses as knowledge of both the universe in general and of mankind itself. We are not the subjects of the universe, but share, with the Creator, the assigned duties of man's being the master of that which man's own development has implicitly assigned him to manage.

So, rather than being the victim of our own ignorant blind faith in the literal readings of the senses, we treat those senses and the added instrumentalities we devise to similar purpose, as merely the instruments, not the content of knowledge. Our primary obligation is to be recognized in our nature as human, as the gardener who responds not only to the demands of the existing garden, but to designing those innovations which will improve it. To be in the image of the Creator, is to create.